

Cabinet LED Control

CVO

Sensor Switch Synchronous 6CH LED Junction Box

Features

- Dimming interface: sensor switch
- Match with a variety of induction sensor head optional
- 12-24VDC Input
- 6 channel synchronous constant voltage output, Max. total output power 60W
- Ultra-thin design, light weight and high efficiency
- Suitable for indoor LED lighting application
- 5 Year, 50,000hr warranty

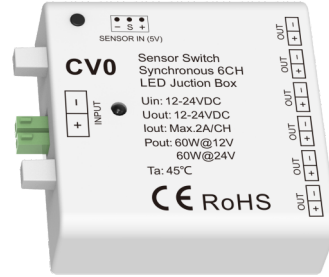

Applications

- Suitable for cabinet LED strip.

CE RoHS

Mechanical Structures and Installations

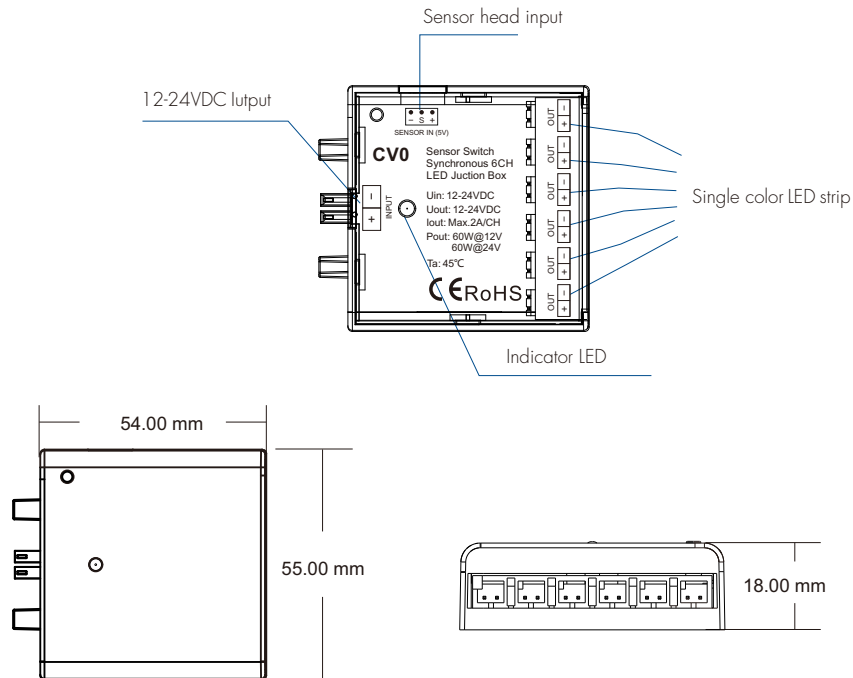

Wiring Diagram

1. Use alone, powered by switching power supply, with or without sensor head

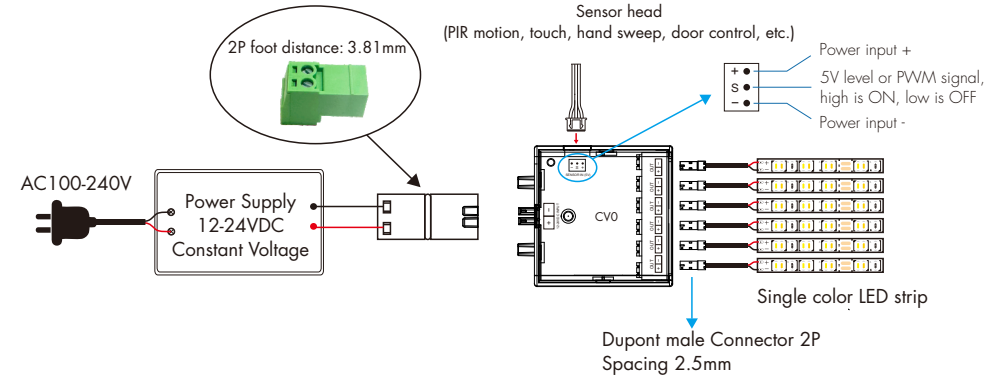

2. Matching cabinet LED driver use, with or without sensor head

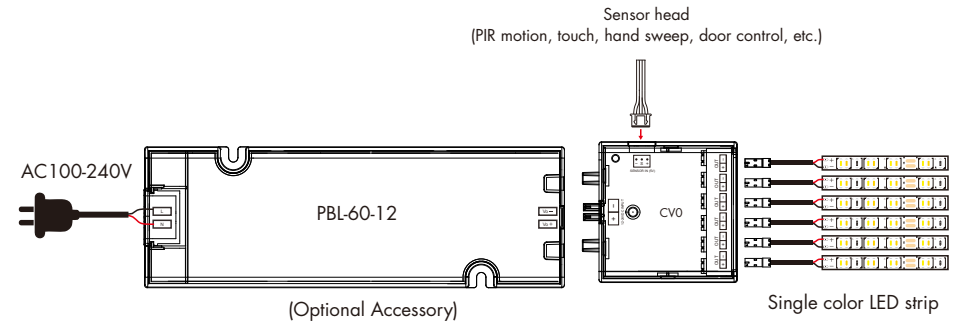

Failure analysis and troubleshooting

| Fault | Cause | Solution |
|--------------------------------|--------------------------------|---|
| The light can not be turned on | 1. No power 2. Wrong wiring | 1. Check the power supply 2. Connection test |
| Hiccup flashing | Over load | Check the power of the light |

Packing List



LED Control Box
1 pcs

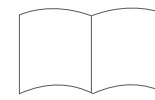

User Manual
1 pcs



2P Terminal
1 pcs



Slotted
screwdriver
1 pcs