

24 Channel Constant Voltage DMX512 & RDM Decoder

Model No.: D24

RDM/Stand-alone function/Six PWM frequencies/Linear or logarithmic dimming/Numeric display/Din Rail

Features

- Comply with the DMX512 standard protocols.
- Digital numeric display, set DMX decode start address by buttons.
- RDM function can realize intercommunication between DMX master and decoder. For example, DMX decoder address can be set by DMX master console.
- 16bit (65536 levels) /8bit (256 levels) grey level selectable.
- PWM frequency 500/1000/2000/4000/8000/16000Hz selectable.
- Logarithmic or linear dimming curve selectable.
- Stand-alone 24-channel RGB mode and 24-channel dimmer mode selectable, which are controlled by buttons with built-in programs, instead of DMX signal.



Technical Parameters

Input and Output	
Input voltage	12-24VDC
Input current	60.5A
Output voltage	24 x (12-24)VDC
Output current	24CH, 3A/CH Total MAX 60A
Output power	24 x (36-72)W
Output type	Constant voltage

Environment	
Operation temperature	Ta: -30°C ~ +55°C
Case temperature (Max.)	Tc: +85°C
IP rating	IP20

Safety and EMC	
EMC standard (EMC)	ETSI EN 301 489-1 V2.2.3 ETSI EN 301 489-17 V3.2.4
Safety standard (LVD)	EN 62368-1:2020+A11:2020
Certification	CE, EMC, LVD

Warranty and Protection	
Warranty	5 years
Protection	Reverse Polarity

Weight	
Net weight	0.304kg
Gross weight	0.356kg

Mechanical Structures and Installations

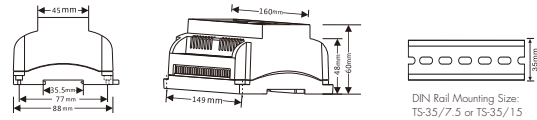
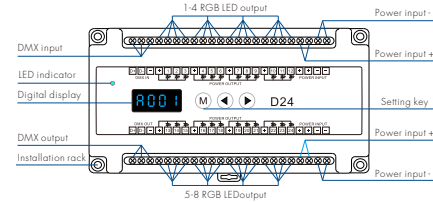

Wiring Diagram

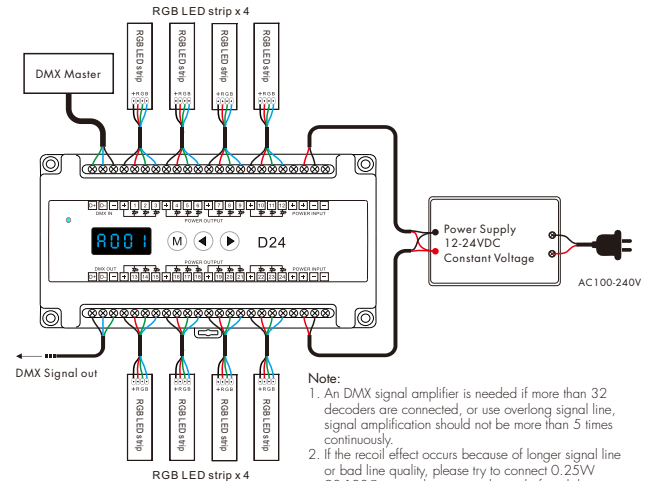

Operation

System parameter setting

- Long press M and ◀ key for 2s, prepare for setup system parameter: decode mode, grey level, output PWM frequency, output brightness curve, default output level, automatic blank screen.short press M key to switch six item.
- Decode mode: short press ◀ or ▶ key to switch 1-channel decode("d-1"), 3-channeldecode("d-3"), 6-channel decode("d-6") or 24-channel decode("d-24").When set as 1 channel decode, and 24 channel output the same brightness of this DMX address.
- Grey level: short press ◀ or ▶ key to switch 8bit("b08") or 16 bit("b16"). choose 16 bit if the DMX master support 16 bit.
- Output PWM frequency: short press ◀ or ▶ key to switch 500Hz("F05"), 1000Hz("F010"), 2000Hz("F020"), 4000Hz("F040"), 8000Hz("F080") or 16000Hz("F160"). Higher PWM frequency, will cause lower output current, higher power noise, but more suitable for camera(No flickers for video).
- Output brightness curve: short press ◀ or ▶ key to switch linear curve("C-L") or logarithmic curve("C-E").
- Default output level: press ◀ or ▶ key to change default 0-100% level ("d00" to "dFF") when no DMX input signal.
- Automatic blank screen: short press ◀ or ▶ key to switch enable ("bon") or disable("boFF")automatic blank screen.
- Long press M key for 2s or timeout 10s, quit system parameter setting.

DMX mode

- Short press M key, when display A001~A512, enter DMX mode.
- Press ◀ or ▶ key to change DMX decode start address(001~512), long press for last adjustment.
- If there is a DMX signal input, will enter DMX mode automatically.
- DMX Dimming: Each D24 DMX decoder occupy 24 DMX address when connecting the DMX console. For example, the defaulted start address is 1, their corresponding relationship in the form:



DMX Console	DMX Decoder Output
CH1 0-255	CH1 PWM 0-100% (LED 1#R)
CH2 0-255	CH2 PWM 0-100% (LED 1#G)
CH3 0-255	CH3 PWM 0-100% (LED 1#B)
⋮	⋮
CH24 0-255	CH24 PWM 0-100% (LED 8#B)

Stand-alone RGB mode

- Short press M key, when display P-1~P-4, enter stand-alone RGB mode.
- Press ◀ or ▶ key to change dynamic mode number(P-1~P-4).
- Each mode can adjust speed and brightness. Long press M key for 2s, prepare for setup mode speed, brightness. Short press M key to switch two item. Press ◀ or ▶ key to setup value of each item. Mode speed : 1-10 level speed(SP-1, SP-9, SP-F). Mode brightness: 1-10 level brightness(br-1, br-9, br-F). Long press M key for 2s, or timeout 10s, quit setting.
- Enter stand-alone RGB mode only when DMX signal is disconnected or lost.



Stand-alone RGB mode
(P--1~P--4)



RGB change mode list

No.	Name
P-1	White forward jump chase
P-2	White forward smooth float
P-3	Red,yellow, green,cyan,blue,purple forward jump chase
P-4	Red,yellow, green,cyan,blue,purple forward smooth float

Stand-alone dimmer mode

- Short press M key, when display L-1~L-8, enter stand-alone dimmer mode.
- Press ◀ or ▶ key to change dimmer mode number(L-1~L-8).
- Each dimmer mode can adjust each channel brightness independently. Long press M key for 2s, prepare for setup 24 channels brightness. Short press M key to switch 24 channels(0100~01FF, 0200~02FF, 0300~03FF, ..., 2400~24FF). Press ◀ or ▶ key to setup brightness value of each channel. Long press M key for 2s, or timeout 10s, quit setting.
- Enter stand-alone dimmer mode only when DMX signal is disconnected or lost.



Stand-alone dimmer mode
(L-1~L-8)

Restore factory default parameter

- Long press ◀ and ▶ key for 2s, restore factory default parameter, display"RES".
- Factory default parameter: DMX decode mode, DMX decode start address is 1, 24 channel decode, 8 bit grey level, 2000Hz PWM frequency output, logarithmic brightness curve, output 100% level when no DMX input, RGB mode number is 1, dimmer mode number is 1, disable automatic blank screen.

Dimming curve setting

Linear dimming curve

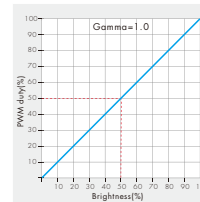

Logarithmic dimming curve

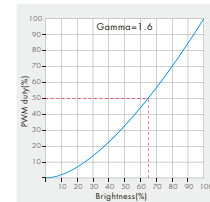

Malfunctions analysis & troubleshooting

Malfunctions	Causes	Troubleshooting
No light	1. No power. 2. Wrong connection or insecure.	1. Check the power. 2. Check the connection.
Wrong color	1. Wrong connection of R/G/B wires. 2. DMX decode address error.	1. Reconnect R/G/B wires. 2. Set correct decode address.
Uneven intensity between front and rear,with voltage drop	1. Output cable is too long. 2. Wire diameter is too small. 3. Overload beyond power supply capability. 4. Overload beyond controller capability.	1. Reduce cable or loop supply. 2. Change wider wire. 3. Replace higher power supply. 4. Add power repeater.